

REVISIONS		DESCRIPTION	DATE	DE	MFG	QA
Q1	1	SEE BELOW				
Q2	1	SEE BELOW				

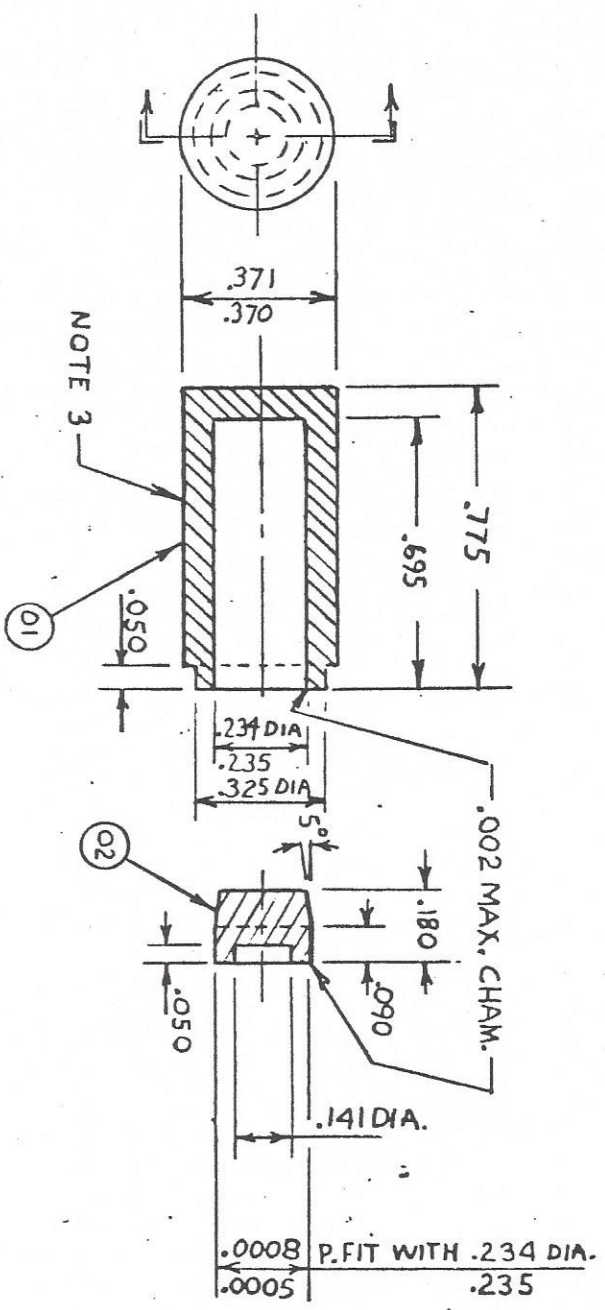

- NOTES:
1. Break all corners .010-.020 unless otherwise specified.
  2. TIG weld. minimum 0.050 weld penetration.
  3. Electroetch, engrave, or Imprint identification marking no more than .005 deep on surface indicated.

ALL DIMENSIONS ARE IN X INCHES ( ) MILLIMETERS

OTHERS OTHERWISE SPECIFIED	
TOLERANCES	FRACTIONS
DIMENSIONS	
XXX .005	ANGLES
XXXX BASIC	30°
ALL SURFACES R/	
MATERIAL: 304L S.S. PER	
ASTM A276 OR A479	
QA	7/2/82
MFG	
DE	
DRAWN	9/2/86
SIGNATURE	
DATE	

FRONTIER TECHNOLOGY CORPORATION

Xenia, Ohio, U.S.A.

Standard Neutron Source  
Model 100 SNS Capsule

SCALE 2X WT. CALC. CODE IDENT NO.

DWG. NO. A10100-PA04  
SHEET OF REV 0